

DATA SHEET

SSTVN16859

13-bit 1:2 SSTL_2 registered buffer for DDR

Product data sheet

2004 Jul 15

13-bit 1:2 SSTL_2 registered buffer for DDR

SSTVN16859

FEATURES

- Stub-series terminated logic for 2.5 V V_{DD} (SSTL_2)
- Designed for PC1600–PC2700 (at 2.5 V) and PC3200 (at 2.6 V) applications
- Pin and function compatible with JEDEC standard SSTV16859
- Supports SSTL_2 signal inputs as per JESD 8–9
- Flow-through architecture optimizes PCB layout
- ESD classification testing is done to JEDEC Standard JESD22. Protection exceeds 2000 V to HBM per method A114.
- Latch-up testing is done to JEDEC Standard JESD78, which exceeds 100 mA.
- Supports efficient low power standby operation
- Full DDR solution when used with PCKVF857
- Available in 56-terminal HVQFN packages

DESCRIPTION

The SSTVN16859 is a 13-bit to 26-bit SSTL_2 registered driver with differential clock inputs, designed to operate between 2.3 V and 2.7 V for PC1600 – PC2700 applications or between 2.5 V and 2.7 V for PC3200 applications. All inputs are compatible with the JEDEC standard for SSTL_2 with V_{REF} normally at $0.5 \times V_{DD}$, except the LVCMOS reset (\overline{RESET}) input. All outputs are SSTL_2, Class II compatible which can be used for standard stub-series applications or capacitive loads. Master reset (\overline{RESET}) asynchronously resets all registers to zero.

The SSTVN16859 is intended to be incorporated into standard DIMM (Dual In-Line Memory Module) designs defined by JEDEC,

such as DDR (Double Data Rate) SDRAM and SDRAM II Memory Modules. Different from traditional SDRAM, DDR SDRAM transfers data on both clock edges (rising and falling), thus doubling the peak bus bandwidth. A DDR DRAM rated at 133 MHz will have a burst rate of 266 MHz.

The device data inputs consist of different receivers. One differential input is tied to the input pin while the other is tied to a reference input pad, which is shared by all inputs.

The clock input is fully differential (CK and \overline{CK}) to be compatible with DRAM devices that are installed on the DIMM. Data are registered at the crossing of CK going HIGH, and \overline{CK} going LOW. However, since the control inputs to the SDRAM change at only half the data rate, the device must only change state on the positive transition of the CK signal. In order to be able to provide defined outputs from the device even before a stable clock has been supplied, the device has an asynchronous input pin (\overline{RESET}), which when held to the LOW state, resets all registers and all outputs to the LOW state.

The device supports low-power standby operation. When \overline{RESET} is LOW, the differential input receivers are disabled, and undriven (floating) data, clock, and reference voltage (V_{REF}) inputs are allowed. In addition, when \overline{RESET} is LOW, all registers are reset, and all outputs are forced LOW. The LVCMOS \overline{RESET} input must always be held at a valid logic HIGH or LOW level.

To ensure defined outputs from the register before a stable clock has been supplied, \overline{RESET} must be held in the LOW state during power-up.

In the DDR DIMM application, \overline{RESET} is specified to be completely asynchronous with respect to CK and \overline{CK} . Therefore, no timing relationship can be guaranteed between the two. When entering \overline{RESET} , the register will be cleared and the outputs will be driven LOW. As long as the data inputs are LOW, and the clock is stable during the time from the LOW-to-HIGH transition of \overline{RESET} until the input receivers are fully enabled, the outputs will remain LOW.

QUICK REFERENCE DATA

GND = 0 V; $T_{amb} = 25\text{ }^{\circ}\text{C}$; $t_r = t_f \leq 2.5\text{ ns}$

SYMBOL	PARAMETER	CONDITIONS	TYPICAL	UNIT
t_{PHL}/t_{PLH}	Propagation delay; CK to Qn	$C_L = 30\text{ pF}$; $V_{DD} = 2.5\text{ V}$	1.7	ns
C_I	Input capacitance	$V_{CC} = 2.5\text{ V}$	2.8	pF

NOTE:

1. C_{PD} is used to determine the dynamic power dissipation (P_D in μW) $P_D = C_{PD} \times V_{CC}^2 \times f_i + \sum (C_L \times V_{CC}^2 \times f_o)$ where:
 f_i = input frequency in MHz; C_L = output load capacity in pF; f_o = output frequency in MHz; V_{CC} = supply voltage in V;
 $\sum (C_L \times V_{CC}^2 \times f_o)$ = sum of the outputs.

ORDERING INFORMATION

PACKAGES	TEMPERATURE RANGE	ORDER CODE	DWG NUMBER
56-Terminal Plastic HVQFN	0 $^{\circ}\text{C}$ to +70 $^{\circ}\text{C}$	SSTVN16859BS	SOT684-1

13-bit 1:2 SSTL_2 registered buffer for DDR

SSTVN16859

56-TERMINAL CONFIGURATION

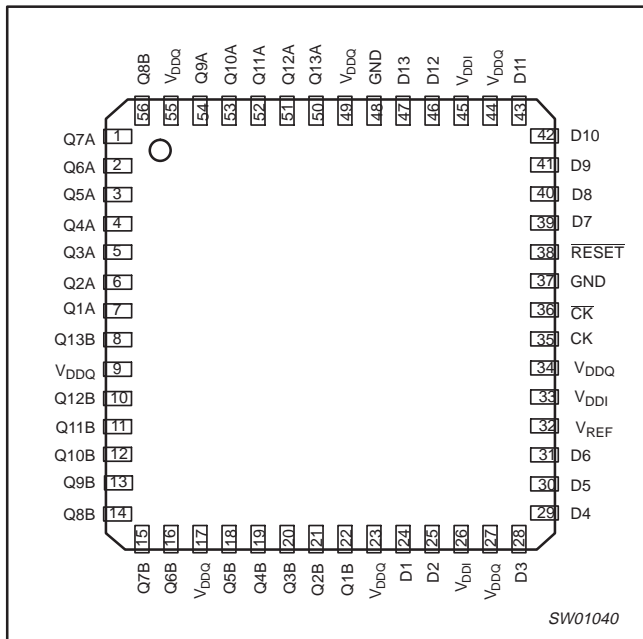

LOGIC DIAGRAM

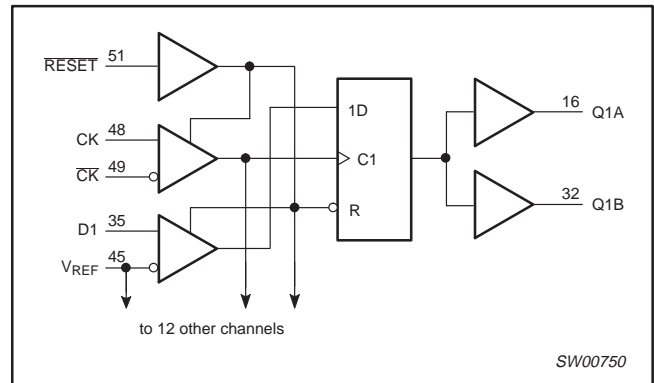

TERMINAL DESCRIPTION

TERMINAL NUMBER	SYMBOL	NAME AND FUNCTION
1, 2, 3, 4, 5, 6, 7, 50, 51, 52, 53, 54, 56	Q13A–Q1A	Data output
10, 11, 12, 13, 14, 15, 16, 18, 19, 20, 21, 22	Q13B–Q1B	Data output
9, 17, 23, 27, 34, 44, 49, 55	V _{DDQ}	Power supply voltage
26, 33, 45	V _{DDI}	Power supply voltage
37, 48	GND	Ground
24, 25, 28, 29, 30, 31, 39, 40, 41, 42, 43, 46, 47	D1–D13	Data input: clocked in on the crossing of the rising edge of CK and the falling edge of CK-bar
32	V _{REF}	Input reference voltage
35, 36	CK, CK-bar	Positive and negative master clock input
51	RESET	Asynchronous reset input: resets registers and disables data and clock differential input receivers

FUNCTION TABLE (each flip flop)

INPUTS				OUTPUT
RESET	CK	CK-bar	D	Q
H	↑	↓	L	L
H	↑	↓	H	H
H	L or H	L or H	X	Q ₀
L	X or floating	X or floating	X or floating	L

H = HIGH voltage level
 L = LOW voltage level
 ↓ = HIGH-to-LOW transition
 ↑ = LOW-to-HIGH transition
 X = Don't care

13-bit 1:2 SSTL_2 registered buffer for DDR

SSTVN16859

ABSOLUTE MAXIMUM RATINGS¹

SYMBOL	PARAMETER	CONDITION	LIMITS		UNIT
			MIN	MAX	
V _{DD}	Supply voltage range		-0.5	+3.6	V
V _I	Input voltage range	Notes 2 and 3	-0.5	V _{DD} + 0.5	V
V _O	Output voltage range	Notes 2 and 3	-0.5	V _{DD} + 0.5	V
I _{IK}	Input clamp current	V _I < 0 V or V _I > V _{DD}	—	±50	mA
I _{OK}	Output clamp current	V _O < 0 V or V _O > V _{DD}	—	±50	mA
I _O	Continuous output current	V _O = 0 V to V _{DD}	—	±50	mA
	Continuous current through each V _{DD} or GND		—	±100	mA
T _{stg}	Storage temperature range		-65	+150	°C

NOTES:

- Stresses beyond those listed under “absolute maximum ratings” may cause permanent damage to the device. These are stress ratings only and functional operation of the device at these or any other conditions beyond those indicated under “recommended operating conditions” is not implied. Exposure to absolute-maximum-rated conditions for extended periods may affect device reliability.
- The input and output negative-voltage ratings may be exceeded if the input and output current ratings are observed.
- This value is limited to 3.6 V maximum.
- The performance capability of a high-performance integrated circuit in conjunction with its thermal environment can create junction temperatures that are detrimental to reliability. The maximum junction temperature of this integrated circuit should not exceed 150°C.

RECOMMENDED OPERATING CONDITIONS¹

SYMBOL	PARAMETER	CONDITIONS	MIN	TYP	MAX	UNIT
V _{DD}	Supply voltage		V _{DD}	—	2.7	V
V _{REF}	Reference voltage (V _{REF} = V _{DD} /2)	PC1600–PC2700	1.15	1.25	1.35	V
		PC3200	1.25	1.3	1.35	V
V _{TT}	Termination voltage		V _{REF} - 40 mV	V _{REF}	V _{REF} + 40 mV	V
V _I	Input voltage		0	—	V _{DD}	V
V _{IH}	AC HIGH-level input voltage	Data inputs	V _{REF} + 310 mV	—	—	V
V _{IL}	AC LOW-level input voltage	Data inputs	—	—	V _{REF} - 310 mV	V
V _{IH}	DC HIGH-level input voltage	Data inputs	V _{REF} + 150 mV	—	—	V
V _{IL}	DC LOW-level input voltage	Data inputs	—	—	V _{REF} - 150 mV	V
V _{IH}	HIGH-level input voltage	RESET	1.7	—	V _{DD}	V
V _{IL}	LOW-level input voltage		0.0	—	0.7	V
V _{ICR}	Common-mode input range	CK, $\overline{\text{CK}}$	0.97	—	1.53	V
V _{ID}	Differential input voltage	CK, $\overline{\text{CK}}$	360	—	—	mV
I _{OH}	HIGH-level output current		—	—	-16	mA
I _{OL}	LOW-level output current		—	—	16	mA
T _{amb}	Operating free-air temperature range		0	—	+70	°C

NOTE:

- The RESET input of the device must be held at V_{DD} or GND to ensure proper device operation. The differential inputs must not be floating, unless RESET is LOW.

13-bit 1:2 SSTL_2 registered buffer for DDR

SSTVN16859

DC ELECTRICAL CHARACTERISTICS—PC1600—PC2700

Over recommended operating conditions. Voltages are referenced to GND (ground = 0 V).

SYMBOL	PARAMETER	TEST CONDITIONS	LIMITS			UNIT	
			T _{amb} = 0 °C to +70 °C				
			MIN	TYP	MAX		
V _{IK}		I _I = -18 mA, V _{DD} = 2.3 V	—	—	-1.2	V	
V _{OH}		I _{OH} = -100 μA, V _{DD} = 2.3 V to 2.7 V	V _{DD} - 0.2	—	—	V	
		I _{OH} = -16 mA, V _{DD} = 2.3 V	1.95	—	—		
V _{OL}		I _{OL} = 100 μA, V _{DD} = 2.3 V to 2.7 V	—	—	0.2	V	
		I _{OL} = 16 mA, V _{DD} = 2.3 V	—	—	0.35		
I _I	All inputs	V _I = V _{DD} or GND, V _{DD} = 2.7 V	—	—	±5	μA	
I _{DD}	Static standby	RESET = GND	I _O = 0 mA; V _{DD} = 2.7 V	—	—	0.01	mA
	Static operating	RESET = V _{DD} , V _I = V _{IH(AC)} or V _{IL(AC)}		—	—	45	
I _{DD}	Dynamic operating – clock only	RESET = V _{DD} , V _I = V _{IH(AC)} or V _{IL(AC)} , CK and CK switching 50% duty cycle.	I _O = 0 mA; V _{DD} = 2.7 V	—	15	—	μA/ clock MHz
	Dynamic operating – per each data input	RESET = V _{DD} , V _I = V _{IH(AC)} or V _{IL(AC)} , CK and CK switching 50% duty cycle. One data input switching at half clock frequency, 50% duty cycle.		—	9	—	μA/ clock MHz/ data input
C _i	Data inputs	V _I = V _{REF} ± 310 mV, V _{DD} = 2.5 V	2.5	2.8	3.5	pF	
	CK and CK	V _{ICR} = 1.25 V, V _{I(PP)} = 360 mV, V _{DD} = 2.5 V	2.5	3.2	3.5		
	RESET	V _I = V _{DD} or GND, V _{DD} = 2.5 V	—	2.4	3.5		

13-bit 1:2 SSTL_2 registered buffer for DDR

SSTVN16859

DC ELECTRICAL CHARACTERISTICS—PC3200

Over recommended operating conditions. Voltages are referenced to GND (ground = 0 V).

SYMBOL	PARAMETER	TEST CONDITIONS	LIMITS			UNIT	
			T _{amb} = 0 °C to +70 °C				
			MIN	TYP	MAX		
V _{IK}		I _I = -18 mA, V _{DD} = 2.5 V	—	—	-1.2	V	
V _{OH}		I _{OH} = -100 μA, V _{DD} = 2.5 to 2.7 V	V _{DD} - 0.2	—	—	V	
		I _{OH} = -16 mA, V _{DD} = 2.5 V	1.95	—	—		
V _{OL}		I _{OL} = 100 μA, V _{DD} = 2.5 to 2.7 V	—	—	0.2	V	
		I _{OL} = 16 mA, V _{DD} = 2.5 V	—	—	0.35		
I _I	All inputs	V _I = V _{DD} or GND, V _{DD} = 2.7 V	—	—	±5	μA	
I _{DD}	Static standby	RESET = GND	I _O = 0 mA; V _{DD} = 2.7 V	—	—	0.01	mA
	Static operating	RESET = V _{DD} , V _I = V _{IH(AC)} or V _{IL(AC)}		—	—	45	
I _{DD}	Dynamic operating – clock only	RESET = V _{DD} , V _I = V _{IH(AC)} or V _{IL(AC)} , CK and CK switching 50% duty cycle.	I _O = 0 mA; V _{DD} = 2.7 V	—	15	—	μA/ clock MHz
	Dynamic operating – per each data input	RESET = V _{DD} , V _I = V _{IH(AC)} or V _{IL(AC)} , CK and CK switching 50% duty cycle. One data input switching at half clock frequency, 50% duty cycle.		—	9	—	μA/ clock MHz/ data input
C _i	Data inputs	V _I = V _{REF} ± 310 mV, V _{DD} = 2.6 V	2.5	2.8	3.5	pF	
	CK and CK	V _{ICR} = 1.25 V, V _{I(PP)} = 360 mV, V _{DD} = 2.6 V	2.5	3.2	3.5		
	RESET	V _I = V _{DD} or GND, V _{DD} = 2.6 V	—	2.4	3.5		

13-bit 1:2 SSTL_2 registered buffer for DDR

SSTVN16859

TIMING REQUIREMENTS—PC1600—PC2700Over recommended operating conditions; $T_{amb} = 0\text{ }^{\circ}\text{C}$ to $+70\text{ }^{\circ}\text{C}$ (unless otherwise noted) (see Figure 1)

SYMBOL	PARAMETER	TEST CONDITIONS	LIMITS		UNIT
			$V_{DD} = 2.5\text{ V} \pm 0.2\text{ V}$		
			MIN	MAX	
f_{clock}	Clock frequency		—	200	MHz
t_w	Pulse duration, CK, $\overline{\text{CK}}$ HIGH or LOW		2.5	—	ns
t_{act}	Differential inputs active time	Notes 1, 2	—	22	ns
t_{inact}	Differential inputs inactive time	Notes 1, 3	—	22	ns
t_{su}	Setup time, fast slew rate (see Notes 4 and 6)	Data before $\text{CK}\uparrow$, $\overline{\text{CK}}\downarrow$	0.65		ns
	Setup time, slow slew rate (see Notes 5 and 6)		0.75		
t_h	Hold time, fast slew rate (see Notes 4 and 6)	Data after $\text{CK}\uparrow$, $\overline{\text{CK}}\downarrow$	0.75		ns
	Hold time, slow slew rate (see Notes 5 and 6)		0.9		

NOTES:

1. This parameter is not necessarily production tested.
2. Data inputs must be below a minimum time of t_{act} max, after $\overline{\text{RESET}}$ is taken HIGH.
3. Data and clock inputs must be held at valid levels (not floating) a minimum time of t_{inact} max, after $\overline{\text{RESET}}$ is taken LOW.
4. For data signal input slew rate $\geq 1\text{ V/ns}$.
5. For data signal input slew rate $\geq 0.5\text{ V/ns}$ and $< 1\text{ V/ns}$.
6. CK, $\overline{\text{CK}}$ signals input slew rates are $\geq 1\text{ V/ns}$.

TIMING REQUIREMENTS—PC3200Over recommended operating conditions; $T_{amb} = 0\text{ }^{\circ}\text{C}$ to $+70\text{ }^{\circ}\text{C}$ (unless otherwise noted) (see Figure 1)

SYMBOL	PARAMETER	TEST CONDITIONS	LIMITS		UNIT
			$V_{DD} = 2.6\text{ V} \pm 0.1\text{ V}$		
			MIN	MAX	
f_{clock}	Clock frequency		—	210	MHz
t_w	Pulse duration, CK, $\overline{\text{CK}}$ HIGH or LOW		2.5	—	ns
t_{act}	Differential inputs active time	Notes 1, 2	—	22	ns
t_{inact}	Differential inputs inactive time	Notes 1, 3	—	22	ns
t_{su}	Setup time, fast slew rate (see Notes 4 and 6)	Data before $\text{CK}\uparrow$, $\overline{\text{CK}}\downarrow$	0.65		ns
	Setup time, slow slew rate (see Notes 5 and 6)		0.75		
t_h	Hold time, fast slew rate (see Notes 4 and 6)	Data after $\text{CK}\uparrow$, $\overline{\text{CK}}\downarrow$	0.65		ns
	Hold time, slow slew rate (see Notes 5 and 6)		0.8		

NOTES:

1. This parameter is not necessarily production tested.
2. Data inputs must be below a minimum time of t_{act} max, after $\overline{\text{RESET}}$ is taken HIGH.
3. Data and clock inputs must be held at valid levels (not floating) a minimum time of t_{inact} max, after $\overline{\text{RESET}}$ is taken LOW.
4. For data signal input slew rate $\geq 1\text{ V/ns}$.
5. For data signal input slew rate $\geq 0.5\text{ V/ns}$ and $< 1\text{ V/ns}$.
6. CK, $\overline{\text{CK}}$ signals input slew rates are $\geq 1\text{ V/ns}$.

13-bit 1:2 SSTL_2 registered buffer for DDR

SSTVN16859

SWITCHING CHARACTERISTICS—PC1600–PC2700

Over recommended operating conditions; $T_{amb} = 0\text{ }^{\circ}\text{C}$ to $+70\text{ }^{\circ}\text{C}$; $V_{DD} = 2.3\text{ V} - 2.7\text{ V}$.
 Class I, $V_{REF} = V_{TT} = V_{DD} \times 0.5$ and $C_L = 10\text{ pF}$ (unless otherwise noted) (see Figure 1)

SYMBOL	FROM (INPUT)	TO (OUTPUT)	LIMITS		UNIT
			$V_{DD} = 2.5\text{ V} \pm 0.2\text{ V}$		
			MIN	MAX	
f_{max}			200	—	MHz
t_{pd}	CK and $\overline{\text{CK}}$	Q	1.1	2.5	ns
t_{pdMSS}	CK and $\overline{\text{CK}}$	Q	—	2.9	ns
t_{PHL}	RESET	Q	1.1	5	ns

SWITCHING CHARACTERISTICS—PC3200

Over recommended operating conditions; $T_{amb} = 0\text{ }^{\circ}\text{C}$ to $+70\text{ }^{\circ}\text{C}$; $V_{DD} = 2.5\text{ V} - 2.7\text{ V}$.
 Class I, $V_{REF} = V_{TT} = V_{DD} \times 0.5$ and $C_L = 10\text{ pF}$ (unless otherwise noted) (see Figure 1)

SYMBOL	FROM (INPUT)	TO (OUTPUT)	LIMITS		UNIT
			$V_{DD} = 2.6\text{ V} \pm 0.1\text{ V}$		
			MIN	MAX	
f_{max}			220	—	MHz
t_{pd}	CK and $\overline{\text{CK}}$	Q	1.1	1.8	ns
t_{pdMSS}	CK and $\overline{\text{CK}}$	Q	—	2.1	ns
t_{PHL}	RESET	Q	1.1	5	ns

PARAMETER MEASUREMENT INFORMATION

TEST CIRCUIT

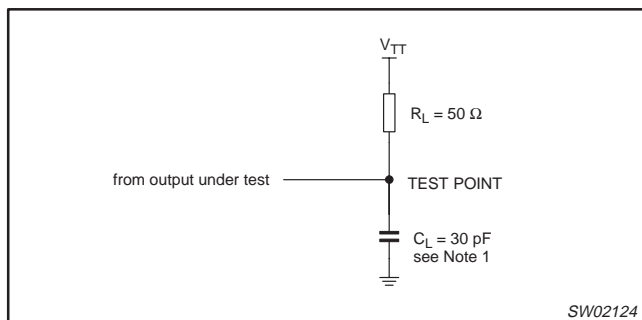

Figure 1. Load circuitry

NOTE:

1. C_L includes probe and jig capacitance.

13-bit 1:2 SSTL_2 registered buffer for DDR

SSTVN16859

AC WAVEFORMS

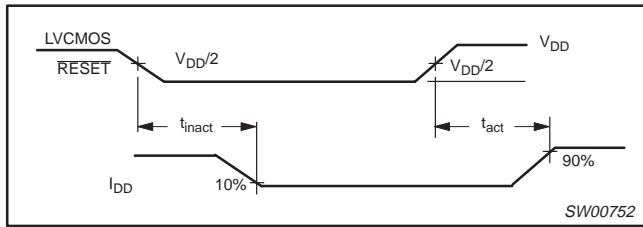

Waveform 1. Inputs active and inactive times (see Note 1)

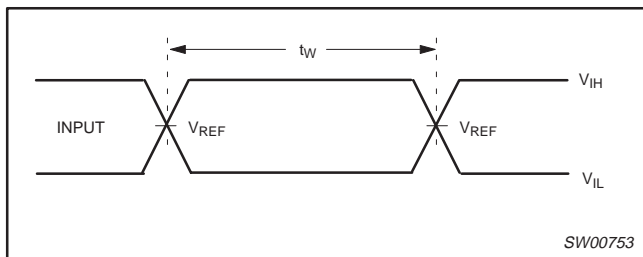

Waveform 2. Pulse duration

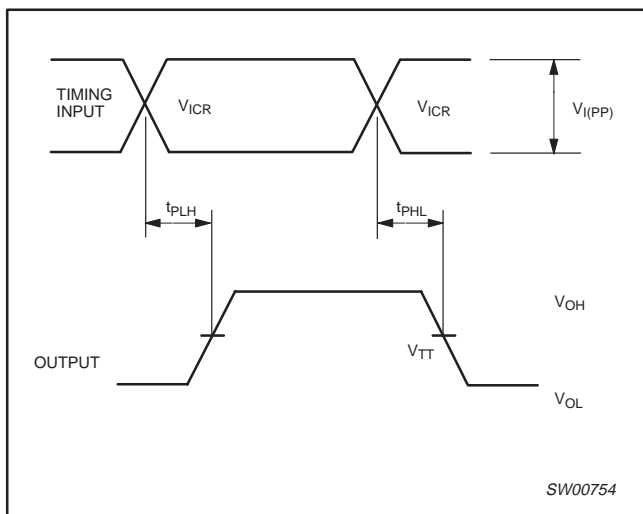

Waveform 3. Propagation delay times

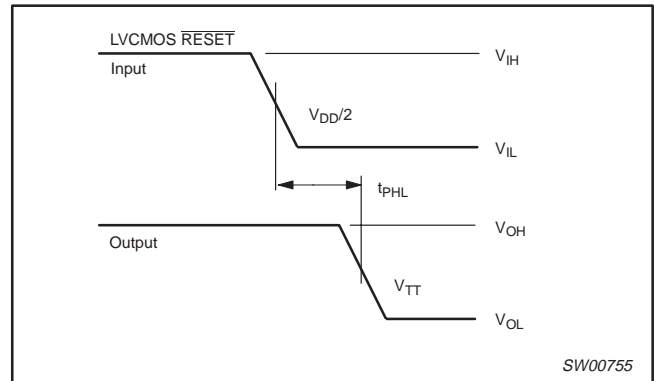

Waveform 4. Propagation delay times

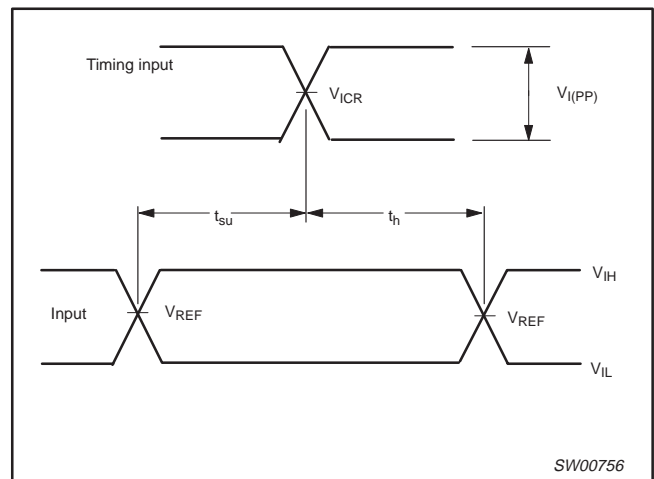

Waveform 5. Setup and hold times

NOTES:

1. I_{DD} tested with clock and data inputs held at V_{DD} or GND, and $I_O = 0$ mA.
2. All input pulses are supplied by generators having the following characteristics: $PRR \leq 10$ MHz, $Z_O = 50 \Omega$, input slew rate = 1 V/ns $\pm 20\%$ (unless otherwise specified).
3. The outputs are measured one at a time with one transition per measurement.
4. $V_{TT} = V_{REF} = V_{DD}/2$
5. $V_{IH} = V_{REF} + 310$ mV (AC voltage levels) for differential inputs. $V_{IH} = V_{DD}$ for LVC MOS input.
6. $V_{IL} = V_{REF} - 310$ mV (AC voltage levels) for differential inputs. $V_{IL} = GND$ for LVC MOS input.
7. t_{PLH} and t_{PHL} are the same as t_{pd} .

13-bit 1:2 SSTL_2 registered buffer for DDR

SSTVN16859

HVQFN56: plastic thermal enhanced very thin quad flat package; no leads; 56 terminals;
body 8 x 8 x 0.85 mm

SOT684-1

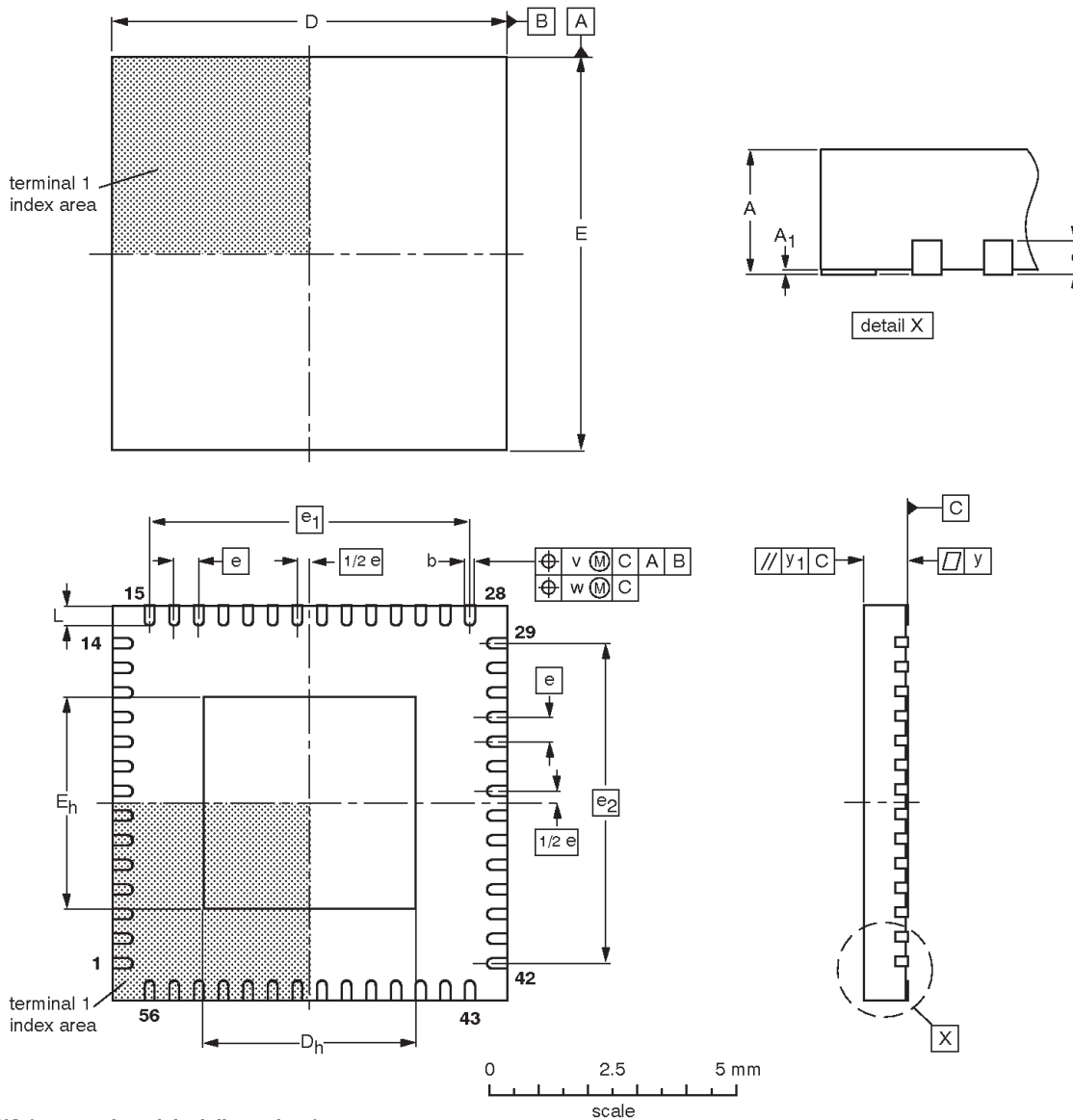

DIMENSIONS (mm are the original dimensions)

UNIT	A ⁽¹⁾ max.	A ₁	b	c	D ⁽¹⁾	D _h	E ⁽¹⁾	E _h	e	e ₁	e ₂	L	v	w	y	y ₁
mm	1	0.05 0.00	0.30 0.18	0.2	8.1 7.9	4.45 4.15	8.1 7.9	4.45 4.15	0.5	6.5	6.5	0.5 0.3	0.1	0.05	0.05	0.1

Note

1. Plastic or metal protrusions of 0.075 mm maximum per side are not included.

OUTLINE VERSION	REFERENCES				EUROPEAN PROJECTION	ISSUE DATE
	IEC	JEDEC	JEITA			
SOT684-1	---	MO-220	---			01-08-08 02-10-22

13-bit 1:2 SSTL_2 registered buffer for DDR

SSTVN16859

REVISION HISTORY

Rev	Date	Description
_1	20040715	Product data sheet (9397 750 13716)

Data sheet status

Level	Data sheet status ^[1]	Product status ^[2] ^[3]	Definitions
I	Objective data sheet	Development	This data sheet contains data from the objective specification for product development. Philips Semiconductors reserves the right to change the specification in any manner without notice.
II	Preliminary data sheet	Qualification	This data sheet contains data from the preliminary specification. Supplementary data will be published at a later date. Philips Semiconductors reserves the right to change the specification without notice, in order to improve the design and supply the best possible product.
III	Product data sheet	Production	This data sheet contains data from the product specification. Philips Semiconductors reserves the right to make changes at any time in order to improve the design, manufacturing and supply. Relevant changes will be communicated via a Customer Product/Process Change Notification (CPCN).

[1] Please consult the most recently issued data sheet before initiating or completing a design.

[2] The product status of the device(s) described in this data sheet may have changed since this data sheet was published. The latest information is available on the Internet at URL <http://www.semiconductors.philips.com>.

[3] For data sheets describing multiple type numbers, the highest-level product status determines the data sheet status.

Definitions

Short-form specification — The data in a short-form specification is extracted from a full data sheet with the same type number and title. For detailed information see the relevant data sheet or data handbook.

Limiting values definition — Limiting values given are in accordance with the Absolute Maximum Rating System (IEC 60134). Stress above one or more of the limiting values may cause permanent damage to the device. These are stress ratings only and operation of the device at these or at any other conditions above those given in the Characteristics sections of the specification is not implied. Exposure to limiting values for extended periods may affect device reliability.

Application information — Applications that are described herein for any of these products are for illustrative purposes only. Philips Semiconductors make no representation or warranty that such applications will be suitable for the specified use without further testing or modification.

Disclaimers

Life support — These products are not designed for use in life support appliances, devices, or systems where malfunction of these products can reasonably be expected to result in personal injury. Philips Semiconductors customers using or selling these products for use in such applications do so at their own risk and agree to fully indemnify Philips Semiconductors for any damages resulting from such application.

Right to make changes — Philips Semiconductors reserves the right to make changes in the products—including circuits, standard cells, and/or software—described or contained herein in order to improve design and/or performance. When the product is in full production (status 'Production'), relevant changes will be communicated via a Customer Product/Process Change Notification (CPCN). Philips Semiconductors assumes no responsibility or liability for the use of any of these products, conveys no license or title under any patent, copyright, or mask work right to these products, and makes no representations or warranties that these products are free from patent, copyright, or mask work right infringement, unless otherwise specified.

Contact information

For additional information please visit
<http://www.semiconductors.philips.com>. Fax: +31 40 27 24825

© Koninklijke Philips Electronics N.V. 2004
 All rights reserved. Printed in U.S.A.

Date of release: 07-04

For sales offices addresses send e-mail to:
sales.addresses@www.semiconductors.philips.com

Document order number:

9397 750 13716

Let's make things better.